

Model

400 Series

TELESCOPIC BOOM LIFTS

Features

Articulating Jib
(460SJ only) 6 ft (1.83 m)
Platform
Side Entry 36 x 96 in. (0.91 x 2.44 m)
Inward Self-Closing Swinging Gate
180 Degree Hydraulic Platform Rotator
Platform Console Machine Status Light Panel*
110V-AC Receptacle in the Platform
5 Degree Tilt Alarm/Indicator Light
12 x 16.5 Rim Protector Lug Tread Tires
Swing Out Engine Tray
12V-DC Auxiliary Power
Hourmeter
Proportional Controls
Control ADE® System
Lifting/Tie Down Lugs
Horn
Oscillating Axle
Operator Tool Tray
Motion Alarm

* Provides indicator lights at platform control console for system distress, low fuel, 5 degree tilt light, and foot switch status

Accessories & Options

750 lb (340 kg) Unrestricted Capacity
with 1,000 lb (450 kg) Restricted
Capacity (400S Only)
36 x 72 in. (0.91 x 1.83 m) Platform
1/2 in. Air Line to Platform
Soft Touch System
14 x 7.5 Lug Tread Tires
Foam-Filled Tires
High Flotation Sand/Turf Tires (4WD Only)
2500W Generator
Tow Package (2WD Only)
Flashing Amber Beacon
43.5 lb (19.73 kg) Propane Tank
Cold Weather Kit
Hostile Environment Kit
Arctic Package
Semi-Trak
Light Package
Platform Worklights

Accessories

SkyPower® Package
SkyWelder® Package
SkyCutter® Package
SkyGlazier® Package (400S only)
Nite Bright® Package
SkyAir® Package (requires SkyPower)
SkyCutter and SkyAir Package
SkyWelder/SkyCutter/SkyAir Combination
(requires SkyPower)
PipeRack

Note: Some options may increase lead time, and some option combinations may not be available.



Increased Productivity

- The fastest lift and drive speeds in their class
- Reaches up to 3.5 ft (1.07 m) further than competitive models
- Improved rough terrain capabilities with 45% gradeability

Enhanced Control

- Exclusive Control ADE® (Advanced Design Electronics) system for better performance with improved serviceability
- Control ADE system allows function speeds and options to be customized to meet customer preferences
- Provides better fuel efficiency, and reduced emissions

Improved Maintainability

- Enhanced electrical system minimizes the number of wires and connections
- The Control ADE system reduces troubleshooting time and identifies potential problems
- Swing-out engine tray provides ease of access

Model 400 Series II

TELESCOPIC BOOM LIFTS

Specifications

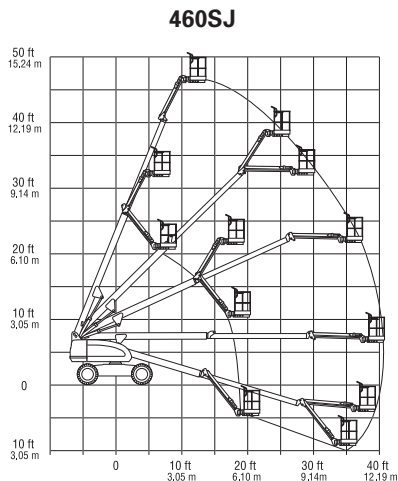
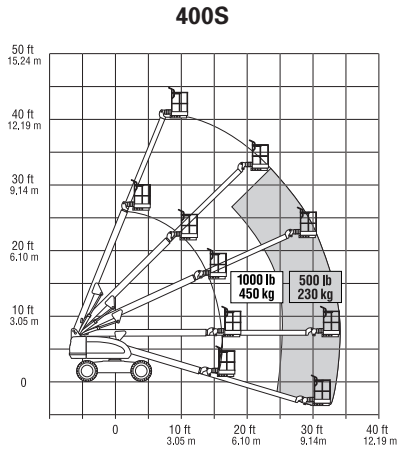

Reach

Platform Height	
400S	40 ft 4 in. (12.3 m)
460SJ	46 ft (14.02 m)
Horizontal Outreach	
400S	34 ft 1 in. (10.4 m)
460SJ	40 ft 6 in. (12.34 m)
Swing	360 Degrees Continuous
Platform Capacity	
Restricted (400S)	1,000 lb (450 kg)
Unrestricted	500 lb (227 kg)
Optional	750 lb (340 kg)
Platform Rotator	180 Degrees Hydraulic
Jib (Range of Articulation)	
460SJ	6 ft (1.83 m), 130 Degrees (+70, -60)
Lift/Lower Speed	29/22 seconds

Dimensions

A. Platform Size	36 x 96 in. (0.91 x 2.44 m)
B. Overall Width	7 ft 6.5 in. (2.30 m)
C. Tailswing	2 ft 10 in. (86 cm)
D. Stowed Height	7 ft 10 in. (2.39 m)
E. Stowed Length	
400S	24 ft 9 in. (7.54 m)
460SJ	29 ft (8.84 m)
F. Wheelbase	7 ft 8 in. (2.34 m)
G. Ground Clearance	
Standard Tires	12.5 in. (32 cm)
14 x 17.5 Tires	13.5 in. (34 cm)
Weight*	
400S	12,525 lb (5,681 kg)
460SJ	15,855 lb (7,192 kg)
Max. Ground Bearing Pressure	58 psi (4.06 kg/cm ²)

Chassis

Drive Speed 2WD/4WD	4.5 mph (7.2 kph)
Gradeability	
2WD	30%
4WD	45%
Turning Radius	
Outside	16 ft 5 in. (5.0 m)
Inside	6 ft 7 in. (2.0 m)
Tire Size/Type	
Standard	12 x 16.5 Pneumatic
Optional	14 x 17.5 Pneumatic

Power Source

Dual Fuel Engine	
GM Vortec 3000 MPFI	82 hp (61 kW)
Diesel Engine	
Deutz F3M1011	48 hp (35.8 kW)
Diesel Engine	
Caterpillar C2.2	50 hp (37.2 kW)
Fuel Tank Capacity	26 gal. (98.5 L)
Hydraulic Reservoir	42 gal. (159 L)
Auxiliary Power	12V DC

* Certain options or country standards will increase weight.

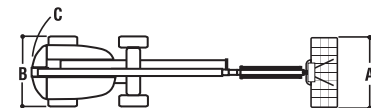
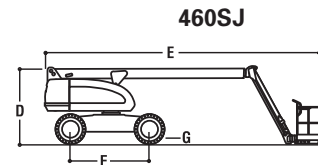
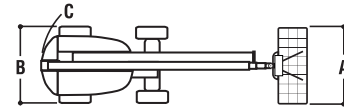
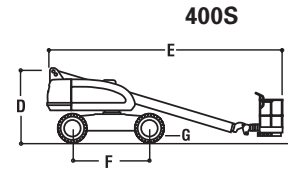

The JLG "1 & 5" Warranty

JLG Industries, Inc. backs our 400 Series boom lifts with our exclusive "1 & 5" Warranty. We provide coverage for one (1) full year, and cover all specified major structural components for five (5) years. These machines meet or exceed applicable OSHA Regulations in 29 CFR 1910.67, 29 CFR 1926.453, ANSI A92.5-2000 and CSA standard B354.4-02 as originally manufactured for intended applications. We reserve the right to make price, specification, and/or equipment changes without prior notification.



JLG Industries, Inc.

An Oshkosh Truck Corporation Company
1 JLG Drive
McConnellsburg, PA 17233-9533
Telephone 717-485-5161
Toll-free in US 877-JLG-LIFT
Fax 717-485-6417
www.jlg.com